

MATERIAL: SEE B/M
 DRAWN: TFK
 SCALE: NONE
 CHECKED: DEP
 DATE: 9-15-95



SIGHT WINDOW
 W-5000

Section: T400
 Bulletin: T400.53
 Date: 12/01/00
 Supersedes: 11/10/98

150 PSIG MODELS

FILE NO.: T400-53.DWG

SIZE (IN)	CONSTANT DIMENSIONS								WEIGHT	
	A		B		C		D		LBS.	KG.
	IN	mm	IN	mm	IN	mm	IN	mm		
1	4.25	108	1.38	34.9	1.25	31.8	1.62	41.3	6.0	2.7
1-1/4	4.62	117	1.38	34.9	1.38	34.9	1.62	41.3	7.0	3.2
1-1/2	5.00	127	2.00	50.8	1.62	41.3	1.75	44.4	9.0	4.0
2	6.00	152	2.00	50.8	1.75	44.4	1.75	44.4	13.0	5.9
2-1/2	7.00	178	3.00	76.2	2.12	54.0	1.88	47.6	20.0	9.0
3	7.50	190	3.19	81.0	2.38	60.3	1.75	44.4	23.0	10.4
4	9.00	229	4.25	108	2.38	60.3	2.00	50.8	34.0	15.4
5	10.00	254	5.00	127	2.38	60.3	2.50	63.5	38.0	17.2
6	11.00	279	6.06	154	2.50	63.5	2.50	63.5	48.0	21.7
8	13.50	343	7.98	203	3.00	76.2	2.88	73.2	58.0	26.3

PARTS LIST				
PIECE NO.	NAME OF PART	QTY	MATERIAL	COMMENTS
1	WELD NECK	1	SEE BELOW	
2	RETAINER	1	STEEL	
3	WINDOW	1	BOROSILICATE	
4	GASKET	1		
5	CUSHION	1	FIBER	
6	BOLT		STEEL	
7	NUT		STEEL	

THIS DRAWING AND ALL INFORMATION ON IT IS THE PROPERTY OF JACOBY-TARBOX, DIVISION OF THE CLARK-RELiance CORPORATION. IT IS CONFIDENTIAL AND IS GIVEN TO YOU FOR A LIMITED PURPOSE AND MUST BE RETURNED UPON REQUEST. NEITHER THIS DRAWING NOR ANY PART OF IT NOR ANY INFORMATION CONCERNING IT MAY BE COPIED, EXHIBITED OR FURNISHED TO OTHERS NOR MAY PHOTOGRAPHS BE TAKEN OF ANY ARTICLE FABRICATED OR ASSEMBLED FROM THIS DRAWING WITHOUT CONSENT OF THE CLARK-RELiance CORPORATION.

OPTIONS

DUAL UNIGLAS WINDOWS

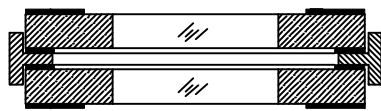

FULL VIEW DUAL WINDOWS



UNIGLAS WINDOW

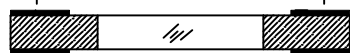

Approved

# OF STUDS	
SIZE(IN)	STUDS
1	4
1-1/4	4
1-1/2	4
2	4
2-1/2	4
3	4
4	8
5	8
6	8
8	8

STANDARD DESIGN MATERIALS:

BODY: ASTM/ASME A-105 (STEEL)
 ASTM/ASME A-182 (316 SS)

RETAINER:

ASTM A-278 (IRON)
 ASTM A-105/A-516-70/A-216-WCB (STEEL)

FASTENERS: SAE GR.5 (STEEL)

304/316 SS TRIM AVAILABLE

OPTIONAL ALLOYS FURNISHED UPON REQUEST

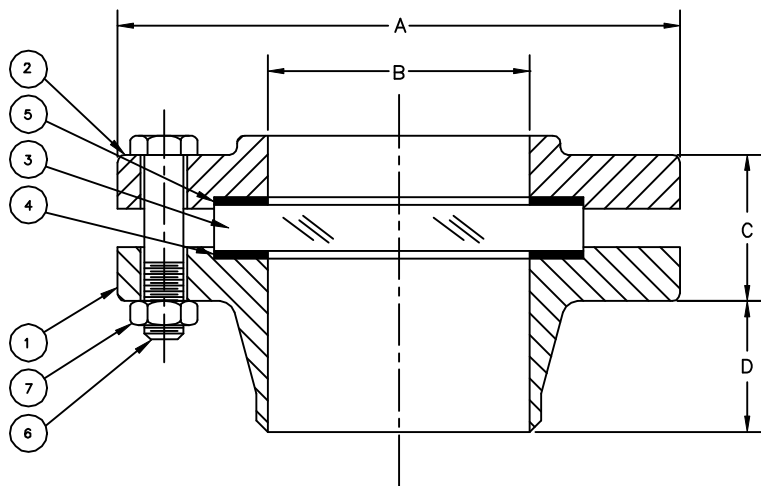

STYLE W-5000

RETAINER PATTERN SHOWN WITH OPTIONAL SS SPRAY RING

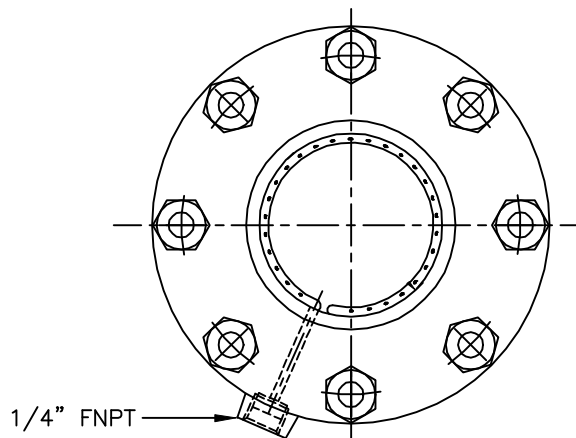

PRESSURE/TEMP. RATINGS

TEMP F	150 PSIG MODELS	
	STEEL	316 SS
-20 TO 100	150	150
150	150	150
200	150	150
250	150	150
300	150	150
350	150	150
400	150	150
450	150	150
500	150	150