

Northeast Controls Incorporated
P.O. Box 275 - 123 Pleasant Avenue
Upper Saddle River, New Jersey 07458 USA
Tel: 201-327-7660 | Fax: 201-327-3242 |
sales@nciweb.net

ACM

INDUSTRIES, INC.



**DIRECT
READING
FLOWMETERS
FOR LIQUIDS
AND GASES**

ISO-9001



DNV

CERTIFICATED FIRM



In 1966 Roy C. Marker was a field engineer for Applied Radiation. On a tour at a NASA facility in Texas, he was briefly shown a large panel of non-functioning flow gauges of various types and sizes. His tour guide pointed out how a majority of gauges were either inaccurate, non-functioning or in the process of repair. His guide then said that a basic, sturdy, dependable flow gauge would be a major benefit to the industry. After this trip Roy challenged himself to come up with a simple flow meter which was rugged and reliable, was easy to apply and install and would give years of service. After developing the Flo-Gage, he launched RCM Industries in 1972 to provide this flow meter to the market. After Roy's untimely death, his wife Lenore Marker managed the business until her retirement in 1987.

Our staff today includes many of Roy's original staff from the 1970's.

GUARANTEE

Our products are guaranteed to satisfy-period. Order what you want, try it for 30 days. If you are not completely satisfied, return it for full refund or credit. Products are further

guaranteed against defects in materials and workmanship for a period of one year.

QUALITY POLICY

Our policy is to supply products which meet or exceed the expectations of our customers and all established requirements. We are committed to continued improvement of our people, our services, our processes and our products.

MISSION

Our mission is to serve industrial and commercial customers with flow measuring products which are rugged and reliable and easy to apply, and provide outstanding service with delivery commitments which are as reliable as our products.

FLO-GAGE™ DIRECT READING FLOWMETERS



The RCM Flo-Gage™ is a direct reading flow meter with a large, easy to read dial calibrated in engineering units (GPM, SCFM, l/m, etc.). The Flo-Gage measures flow based on a pressure differential created across a built-in calibrated nozzle. The meter is self-contained and complete. It does not require external

Remote Readout (Option R2)

Northeast Controls Incorporated
P.O. Box 275 - 123 Pleasant Avenue
Upper Saddle River, New Jersey 07458 USA
Tel: 201-327-7660 | Fax: 201-327-3242 | sales@nciweb.net
http://www.nciweb.net



power connections, separate orifices, or blocking, purging or equalizing valves.

The Flo-Gage is suitable for measuring water, oil and most other low viscosity liquids which do not deposit out and which are compatible with the materials of construction. The Flo-Gage is also suitable for measuring compressed air, oxygen, carbon dioxide and many other non-toxic compressed gases. (Specify Option I). Saturated steam can also be measured up to 120 psig. (Option K).

The Flo-Gage can be fitted with a transmitter with current or frequency outputs for remote indication or totalization, or with reed switch contacts for signaling high or low flows.

APPLICATIONS

The Flo-Gage flowmeter has been developed for industrial applications where durability and reliability are important considerations

in the monitoring of flow. The Flo-Gage has accuracy for most industrial processes and is particularly suited for applications where compactness, low cost, minimal maintenance and resistance to accidental damage are important factors.

Typical applications include: lube oil monitoring, blending processes, cooling water, reverse osmosis systems and compressed air measurement.

FEATURES

- Sturdy, in-line, metal construction to withstand piping stresses
- Dial won't crack, glaze or become hard to read
- Expanded analog 270° dial for reading at a glance
- Large 3.5" (90mm) dial
- Suitable for use with both opaque and clear fluids
- Measures 6:1 range with $\pm 3\%$ F.S. accuracy

APPLICATION CONSIDERATIONS

SLURRIES AND SUSPENDED SOLIDS

Liquids with finely dispersed solids in suspension can be metered successfully provided:

- A) Solids content is low enough to permit line fluids to behave as a low viscosity liquid.
- B) Specific gravity effects are accounted for.
- C) Solids do not plug up the pressure ports.
- D) Abrasive action does not erode meter nozzle.

SERVICES NOT RECOMMENDED

Flo-Gages are not recommended for the following kinds of services:

- A) Resins, paints or monomers which can form solid deposits in the piping system.
- B) "Super-solvents" which attack most available elastomer O-ring seals.
- C) Sulfuric acid in any concentration.
- D) Foams which tend to have inconsistent densities.
- E) Foods and pharmaceuticals which require crevice free construction for clean-in-place sterilization.
- F) Toxic substances requiring hermetically sealed enclosures.
- G) Viscous fluids (more than 500 centipoises) which affect meter accuracy at low flow rates.
- H) Pumping systems using piston pumps which produce non-steady flow conditions.
- I) Gravity-fed systems having less head than the pressure loss across the meter at normal operating conditions.

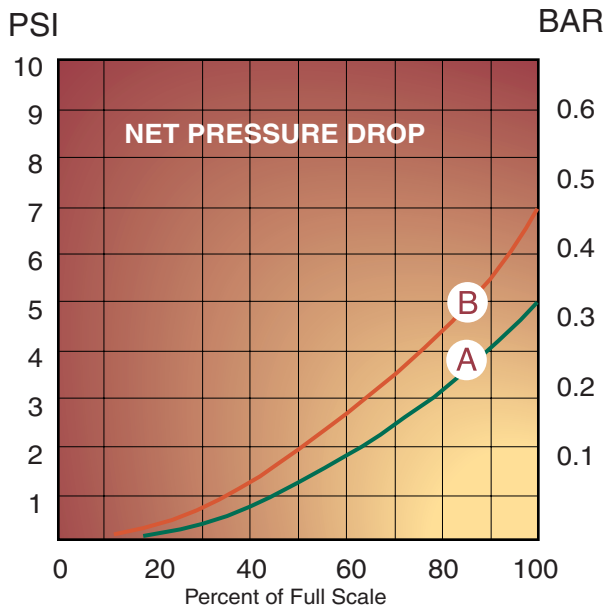

PRESSURE DROP CHARACTERISTICS

<u>Meter Material</u>	<u>Curve</u>
Bronze	A
Monel	B
Stainless Steel	B
Option H (400 psig)	B

COOLING SYSTEMS FOR MACHINERY

Monitor correct cooling flow to machinery. Protect valuable equipment by using a low flow switch to shut down machinery before damage. The Flo-Gage will not foul with small debris frequently found in cooling systems. Fouling can cause typical flow switches to stick and fail to detect low flow conditions.

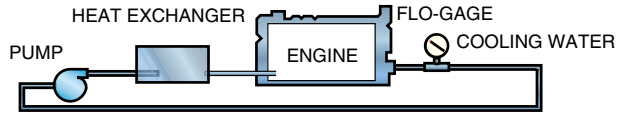

MONITOR LUBRICATION OIL TO TURBINES AND OTHER EXPENSIVE EQUIPMENT

Flo-Gages are ideal for measuring lube-oil. They do not require that the oil be transparent to be measured. Low flow switches can add additional protection.

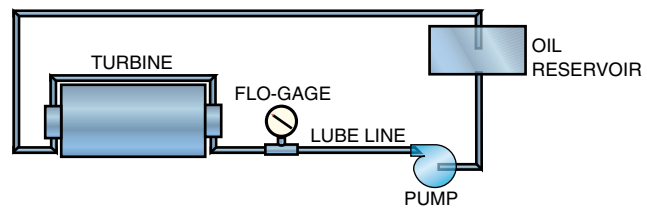

PROCESS CONTROL

Use a Flo-Gage to measure the optimum flow rate for cooling water under various load conditions. The Flo-Gage can then be used to quickly set the most economical flow rate.

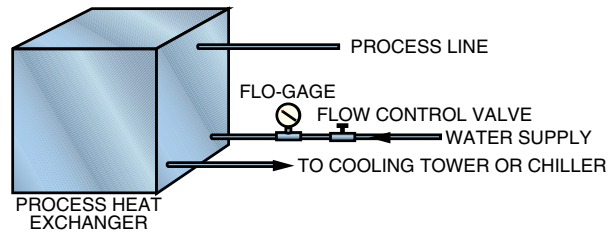

MONITOR CUTTING OIL FLOW IN AUTOMATIC MACHINING CENTERS

Proper flow of cutting oil is essential to machining operations. Automatic machines which run unattended require monitoring of the flow of cutting fluids. The gage allows quick setting of the proper flow rate. The low flow switch can stop machines before bad parts are produced.

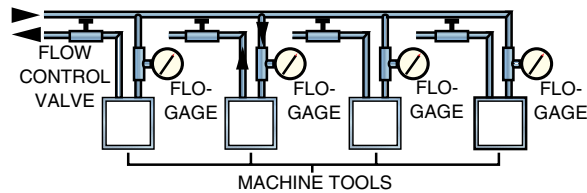

COMPRESSED AIR MONITORING FOR ENERGY CONSERVATION

Mount a Flo-Gage downstream of a pressure regulator to monitor compressor operation and air utilization. Flo-Gages can be used at the compressor as well as at key distribution points. Reduction in wasted air can pay back installation cost in as little as a few weeks.

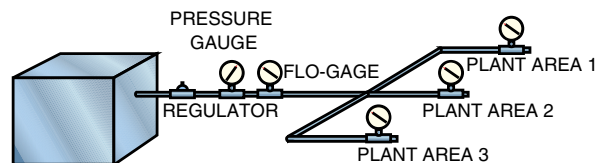



lecting the Flo-Gage is easy...and our factory staff is always glad to help!

Select a) body size, b) mounting method, c) body material, d) direction of flow, e) full scale flow rate, f) options (if required) and g) switches (if required).

A) BODY SIZE - pipe size at the meter inlet. Select from Standard Flow Rates and Body Sizes, page 6.

B) SERIES (mounting method)
7 - threaded units provided with FNPT connections standard. (FBSP parallel threads available on request for bronze and monel meters.)
8 - wafer units mount between any standard 150 or 300 class flanges (or international equivalent).

C) MATERIAL -
1 = Bronze **2** = Monel

3 = Stainless steel (316)

D) FLOW DIRECTION – Select L, R, VUL, VUR, VDL, VDR (see diagram below)

E) FLOW RATE (full scale) - Select from Standard Flow Rates and Body Sizes, page 6. Prefix full scale with “M” for metric units.

F) OPTIONS (if required) - Select from table of Options. Note: For gas service, select option I and specify gas being measured, inlet temperature and pressure.

G) SWITCHES (if required)

1S2 - One single pole double throw switch

2S2 - Two single pole double throw switches

EXAMPLE: 3/4-71-R-20-AD-1S2 is the catalog number for a 3/4” NPT Series 7000 Flo-Gage of bronze construction, flow direction from left to right, flow range of 20 GPM full scale, equipped with optional seals of Viton, optional gasketed case and one single-pole double throw reed switch.

Example $\frac{3}{4}$ " - 7 1 - R - 20 - AD - 1S2
a b c d e f g

Meter housing and indicator may be rotated to any one of four positions at 90° spacing. Provide 10 pipe diameters of straight approach up-stream of the meter.

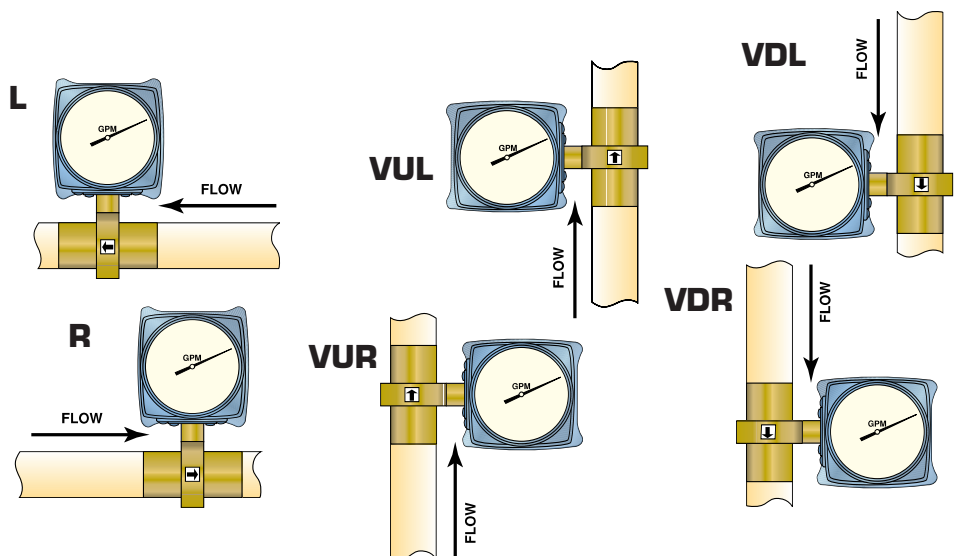

STANDARD FLOW RANGES & BODY SIZES

Charts indicate the various full scale flow rates available as standard for each body size. See page 11 for minimums.

SERIES 7000 (THREADED) AND SERIES 8000 (WAFER)

Size		Full Scale Flow Range				
		liquid		gas		steam
in	mm	GPM	l/m	SCFM	Nm ³ /h	#/h
1/4	08	2	8	10	15	40
1/4	08	3	15	20	30	60
1/4	08	4	25	30	50	80
1/2	15	2	8	10	15	40
1/2	15	3	10	20	30	60
1/2	15	4	15	30	50	80
1/2	15	6	25	40	80	120
1/2	15	10	40	60	100	200
3/4	20	6	25	60	100	120
3/4	20	10	40	100	150	200
3/4	20	15	60	150	200	300
3/4	20	20	80	200	300	400
1	25	15	60	150	250	300
1	25	20	80	200	400	400
1	25	30	120	300	500	600
1	25	40	150	400	600	800
1-1/2	40	30	120	300	500	600
1-1/2	40	40	150	400	600	800
1-1/2	40	60	240	600	1000	1000
1-1/2	40	100	400	800	1200	2000
2	50	40	150	400	600	800
2	50	60	240	600	1000	1000
2	50	100	400	800	1200	2000
2	50	150	600	1000	1500	3000
2	50	200	800	1200	2000	4000
3	80	200	800	1000	1500	4000
3	80	300	1000	2000	3000	6000
3	80	400	1500	3000	5000	8000
3	80	500	2000	4000	6000	10000

* Note: 1/4 in. size is available in Series 7000 only

SERIES 8000 ONLY (WAFER)

Size		Full Scale Flow Range				
		liquid		gas (option 1)		steam
in	mm	GPM	l/m	SCFM	Nm ³ /h	#/h
2-1/2	65	60	240	600	1000	1000
2-1/2	65	100	400	800	1200	2000
2-1/2	65	150	600	1000	1500	3000
2-1/2	65	200	800	1200	2000	4000
4	100	300	1000	1500	50	6000
4	100	400	1500	3000	100	8000
4	100	600	2400	5000	150	10000
4	100	800	3000	6000	200	15000
5	125	300	1000	1500	50	6000
5	125	400	1500	3000	100	8000
5	125	600	2400	5000	150	10000
5	125	800	3000	6000	200	15000
6	150	600	2400	3000	100	10000
6	150	800	3000	5000	150	15000
6	150	1000	4000	8000	250	20000
6	150	2000	8000	15000	400	40000
8	200	600	2400	5000	150	10000
8	200	1000	4000	8000	250	20000
8	200	2000	8000	15000	400	40000
8	200	3000	12000	20000	600	60000

OPTIONAL LOW FLOW RATES (OPTION ES)

Size		Full Scale Flow Range				
		liquid			gas	
in	mm	GPH	l/h	cc/m	SCFH	Nm ³ /h
1/2	15	4	15	200	40	1
1/2	15	6	20	300	60	2
1/2	15	10	40	400	100	3
1/2	15	15	60	600	150	4
1/2	15	20	80	1000	200	6
1/2	15	30	120	2000	300	8
1/2	15	40	150	3000	400	10
1/2	15	60	240	4000		
1/2	15	100	400	6000		

OPTIONS

- A Viton seals
- B EPR seals
- B2 Teflon (PTFE) seals
- C Calibration for specific gravity
- D Gasketed case (NEMA-4X, IP-66)
- D2 Gasketed case with conduit (NEMA-4X IP-66)
- E Non-standard flow rate
- ES Low flow rate (below 2 GPM)
- F Aluminum housing with plastic dial crystal
- F2 Aluminum housing with glass dial crystal
- G Custom scales and dials
- H High pressure service
- I Compressed gas service
- J Peak flow indicator
- K Saturated steam service
- N Ammonia service
- P Panel Mount
- RW3 Digital readout (rate and total)
- R2 Remote readout, bronze
- R3 Remote readout, 316 SS
- T Expanded temperature range
- V High viscosity service (5 to 500 cps - specify)
- W 4-20 mA DC (linear)
- W2 4-20 mA DC with local mechanical indicator. (requires external square root extractor)
- W3 4-20 mA dc (same as W2) but no mechanical indicator
- X Hi/Lo alarm relays
- Y Frequency output
- Z Combination of options W, X, Y
- EM European labeling (CE mark)
- IS Intrinsic safety Class I Div. 1 Groups A,B,C,D
- 1S2 1 single throw double pole reed switch
- 2S2 2 single throw double pole reed switches

ACCESSORIES *(see price sheet for details)*

- SK-1 Compressed Air Survey Kit (see p.11)
- DR-1 Remote Digital Readout (requires transmitter)
- PS-24 Power Supply, 115 vAc in 24 Vdc out, 100 mA
- KT-1 Fittings for connecting remote readout, R2
- KT-3 Fittings for connecting remote readout, R3

OPTIONS A & B: O-RING SEALS.

Viton* (option A), EPR (option B) or Teflon* (PTFE) (option B2) O-rings may be supplied in lieu of the standard Buna-N O-ring. See table of "Recommended Meter Materials" (page 12) for suggested materials.

OPTION C: CALIBRATION FOR SPECIFIC GRAVITY

All Flo-Gages are normally calibrated for water with a specific gravity of 1.0 (density of 62.4 lbs./ft.³). This option provides a custom sized orifice to accommodate the actual specific gravity of the measured liquid.

OPTION D: GASKETED METER HOUSING

If the meter is to be exposed to the weather, marine service, splashing liquids, corrosive vapors, or extreme humidity or dusty conditions, then a gasketed meter housing is recommended. Gaskets are installed at the body flange, back cover plate and under the dial crystal to make the housing leak-tight.

OPTION E: NON-STANDARD FLOW RATES. Various full-scale flow rates are available for each pipe size as indicated in the charts of "Standard Flow Rates and Body Sizes". Special orifices can be furnished for smaller flows. Consult factory if this option is desired.

OPTION ES: LOW FLOW RATES

A low flow meter is available with 1/2" female NPT connections for measuring the flow of liquids as low as 1 GPH and gases as low as 10 SCFH.

OPTION G: CUSTOM SCALES AND DIALS

Non-standard flow rates and custom dial patterns require preparation of special artwork. A one-time charge is made for each custom dial pattern or non-standard scale.

OPTION H: 400 PSIG SERVICE

Meters equipped with bellows made of Inconel 718** are available with service ratings to 400 psig and may be used where service conditions permit use of stainless steel. A slight increase in pressure drop across the meter results when these bellows are used. (See page 3.)



* Trademark of E.I. DuPont
** Trademark of International Nickel Co.

OPTION I: COMPRESSED GAS SERVICE.

Meters intended for compressed gas service require individual sizing of meter orifices to suit the desired flow rate, gas composition, line pressure and temperature. Dials are marked with type of gas, specific gravity, line pressure and temperature.

OPTION J: PEAK FLOW INDICATOR.

A second pointer is provided with a reset knob to provide an indication of the maximum flow rate achieved since reset.

OPTION K: SATURATED STEAM SERVICE.

The steam service option includes EPR seals, SS bellows and an inverted aluminum housing. Steam pressures are limited to 120# saturated unless remote mounted (Option R2 and R3).

OPTION N: AMMONIA SERVICE.

This option includes brass free construction throughout, EPR seals, a stainless gear movement and gasketed case. Price includes calibration for specific gravity, pressure and temperature. This option is available for stainless steel models only.

OPTION P: PANEL MOUNT.

The meter may be mounted behind a panel for pipe sizes 1 1/2" and smaller.

OPTION RW3: DIGITAL DISPLAY (RATE AND TOTAL).

A loop powered (4-20mA dc) two-wire indicator displays 4 1/2 digits for flow rate and 8 digits for totalization.

Includes sealed, open collector output for remote totalizer.

Includes square root extraction. Replaces the standard dial indicator. Includes option W3.

Option R2 & R3 Remote Read-out.

Adapters and 3-way equalizing valve provide extended temperature ranges or remote

mount for more convenient viewing.

(Picture page 1.)

OPTION T: EXPANDED TEMPERATURE RANGE.

Materials suitable for a range of -80°F to 350°F are provided. Higher temperatures available in combination with Option R2 and R3. *(Contact Factory.)*

OPTION V: CALIBRATION FOR HIGH VISCOSITY LIQUIDS.

Liquids having high viscosities cause flow meters to read high; however, this effect is slight for liquids having viscosities less than 5 centipoises. Heavy lubricating and fuel oils with viscosities up to 500 cps require special sizing of the flow meter orifice.

Flo Gages are not recommended for metering of fluids with viscosities greater than 500 centipoises. Consult the factory for specific recommendations.



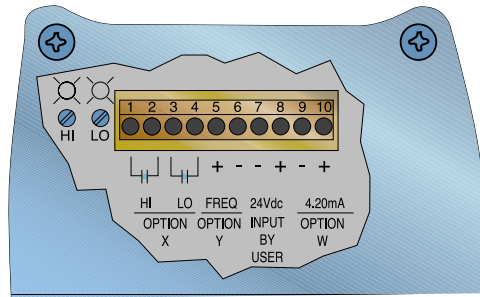

CONNECTION DETAIL W,X,Y,Z

OPTION W : CURRENT OUTPUT.

The RCM Flo-Gage is available with 4-20 mA dc output for interfacing with remote indicators, controllers, computers and alarms. Option W uses a solid state sensor (Hall Effect) to detect the position of the pointer lever mechanism. Low flow cutoff drives the output to 4 mA when flow drops below approximately 30% of full scale.

Output is linear with flow rate.

OPTION W2 AND W3 : CURRENT OUTPUT

Options W2 and W3 use a solid state strain-gauge to sense the differential pressure directly. Option W2 includes a mechanical flow indicator. Option W3 does not. Conditions which could cause the mechanical movement zero to shift will not affect the output from this transmitter. This transmitter provides improved rangeability at low flow rate and accordingly, does not include a low flow cutoff. Output is proportional to flow rate squared (r^2). Square root extraction is required in the receiving device.

Transmitters must be remote mounted if used for high temperature or steam service. Transmitters are not available in combination with options N, -1S2, -2S2.

OPTION X: LIMIT SWITCHES. A pair of limit switches can be ordered to provide high and low limit signals. Relay contacts (N.O.) provide simple connection to electrical interlock circuits or alarm indicators. Potentiometers are provided for adjusting set points. Red and green LEDs indicate relay operation.

OPTION Y: FREQUENCY OUTPUT. A 0-1000 Hz frequency output is available to drive batch controllers or scaled electronic counters. The frequency output becomes 0 Hz whenever the flow rate falls below approximately 30% F.S.

OPTION Z: COMBINATION. This option combines option W, X and Y in the same unit.



OPTION W3 2 WIRE FLOW TRANSMITTER

TRANSMITTERS

REED SWITCHES

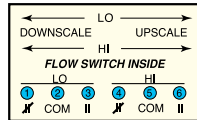
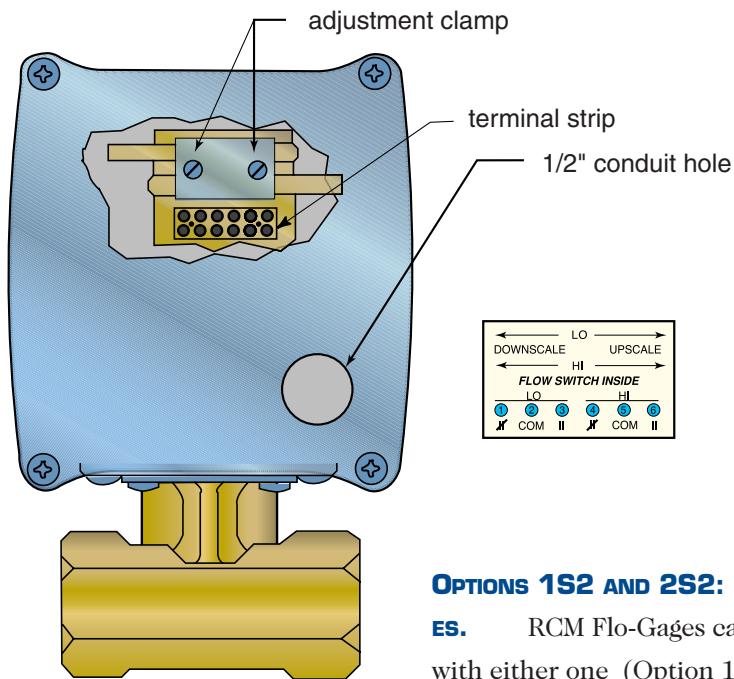

OPTIONS 1S2 AND 2S2: REED SWITCHES.

RCM Flo-Gages can be ordered with either one (Option 1S2) or two (Option 2S2) reed switches suitable for sensing the actual flow rate. The switches make or break contacts by detecting the position of a magnet which is permanently attached to the pointer mechanism on the flow indicator. This technique ensures a constant correlation between the flow rate indicator and the flow switch. In addition it provides extremely reliable flow sensing which is highly immune to fouling by small particles in the flowing liquid.

Each switch is independently adjustable from 30% to 90% of full scale. Switches are factory set to specified flow rates (30% and 90% FS if not specified). Switches are single-pole double-throw for

ease in configuring a safety interlock or control circuit.

Tamper resistant switches are located inside the meter and accessed by removing the back cover. Switches are hermetically sealed in glass and then epoxy potted.

A 1/2" conduit entrance and a built-in terminal strip are provided for ease of connection.

APPLICATIONS. Use a single reed switch set for low flow to protect equipment against loss of cooling or lubrication flow. A high flow switch provides warning of pipeline leaks.

ORDERING INFORMATION. Reed switches are available with all options except, K, N, RW3,W, W2,W3, X, Y and Z.

RECOMMENDED METER MATERIAL

Ratings:

- 1 = Recommended
- 2 = Limited use only
- 3 = Not recommended

	Bronze	Monel	Stainless Steel		Buna-N	Viton	EPR	PTFE
Water								
Deionized water	3	1	1		1	1	1	1
Distilled Water	3	1	1		1	1	1	1
Ethylene-glycol mixtures	1	1	1		1	1	1	1
Fresh water	1	1	1		1	1	1	1
Polluted or brackish water	2	1	2		1	1	1	1
Sea Water	2	1	3		1	1	1	1
Oils and Solvents								
Acetone	1	1	1		3	3	1	1
Chlorinated hydrocarbons	3	1	3		3	1	3	1
Fuel Oils	1	1	1		1	1	3	1
Kerosene	1	1	1		1	1	3	1
Ketones	1	1	1		3	3	1	1
Petroleum oils	1	1	1		1	1	3	1
Phosphate esters (hydraulic fluids)	1	1	1		3	1	1	1
Silicone oils	1	1	1		1	1	1	1
Gases and Vapors								
Acetylene	2	1	1		1	1	1	1
Air	1	1	1		1	1	1	1
Ammonia	3	3	1		3	3	1	1
Argon	1	1	1		1	1	1	1
Carbon dioxide	1	1	1		2	1	2	1
Helium	1	1	1		1	1	1	1
Hydrogen	1	1	1		1	1	1	1
Natural gas	1	1	1		1	1	3	1
Nitrogen	1	1	1		1	1	1	1
Oxygen	1	1	1		3	1	3	1
Chemical Solutions***								
Alkalines	3	1	1		3	2	1	1
Alkaline Salts	3	1	1		3	2	1	1
Ammonia	3	3	1		3	3	1	1
Hydrochloric acid	3	1	3		3	1	3	1
Hydrofluoric acid	3	1	3		3	1	3	1
Hydrogen peroxide	3	3	1		3	1	3	1
Neutral salts	3	1	1		2	1	2	1
Nitric acid	3	3	1		3	1	3	1
Oxidizing compounds	3	3	1		3	1	3	1
Reducing compounds	2	1	3		3	1	3	1
Sulfur compounds	3	3	1		3	1	3	1

***Consult factory for specific recommendations if service conditions involve any of the listed chemicals or other corrosive compounds.

SPECIFICATIONS

FLO-GAGE

Accuracy	±3% F.S.	
Repeatability	±1% F.S.	
	Standard	Optional
Pressure, max.	180 psig (12.6 kg/cm ²)	400 psig, (28.1 kg/cm ²)
Pressure, min.	10 psig (0.67 kg/cm ²)	10 psig, (0.67 kg/cm ²)
Temperature, max.*	212°F (100°C)	350°F (177°C)
Temperature, min.	-30°F (-34°C)	-80°F (-62°C)

*Higher temperature available with Option R2. Consult factory.
Protect from freezing liquids

TRANSMITTER

	(Option W, X, Y, Z)	(Option W2 and W3)
Accuracy		
Horizontal Flow	±3% F.S. above 30% F.S.	±3% F.S. above 15% F.S.
Vertical Flow	±5% F.S. above 30% F.S.	±3% F.S. above 15% F.S.
Ambient temp. limit	120°F, 50°C	120°F, 50°C
Current output	4-20mA into 800 ohms max.	4-20mA into 650 ohms max. (350 ohms max with option RW3)
Contact rating (hi/lo)	3.0 amp @ 24V, 1.0 amp @ 117V, 0.5 amp @ 230V	
Frequency output	1000 Hz F.S. 5 V peak, 270 µs on time	N/A
Electrical rating	General purpose	Intrinsic safety for Class I Div I Groups A,B,C,D; Class II Div I Groups E,F,G; EEx ia IIC T3
	100mA, 24 Vdc per meter.	25mA, 24 Vdc per meter.

REED SWITCHES (Option 1S2, 2S2)

Setability	±5% F.S.
Repeatability	±1% F.S.
Hysteresis	7 to 13% F.S.
Contact Rating	3 watts
Voltage	175 vdc - max. 245 Vac - max.
Current	250mA max. switching 1.0 Amp max. carry

CONSTRUCTION SPECIFICATIONS

	Standard	Options
Housing	Super ABS UV stabilized	None
Body	Bronze	Monel, 316 SS
Bellows	Bronze	Monel, 316 SS, Inconel
Seals	Buna-N	Viton, EPR, Teflon
Crystal	Polycarbonate	None
Gear Movement	Bronze	316 SS

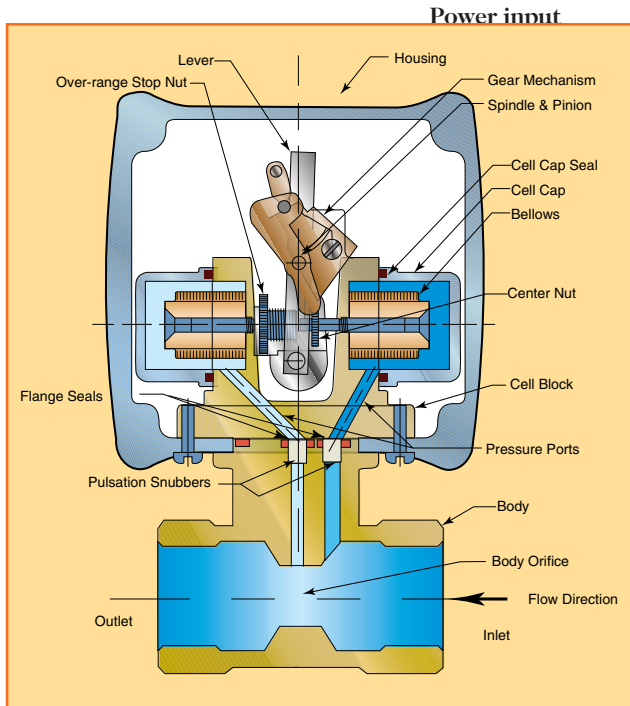

TYPICAL ASSEMBLY OF SERIES 7000 FLO-GAGE

SERIES 7000

Size		A		B		C		D		Shipping Weight (typ.)	
in	mm	in	mm	in	mm	in	mm	in	mm	lb	kg
1/4	08	5.95	151	3.06	78	1.50	38	1.25 hex	32 hex	4	2.3
1/2	15	5.95	151	3.06	78	1.50	38	1.25 hex	32 hex	4	2.3
3/4	20	5.95	151	3.06	78	1.50	38	1.25 hex	32 hex	4	2.3
1	25	6.07	154	3.06	78	1.75	44	1.50 hex	38 hex	5	2.7
1-1/2	40	6.39	162	3.06	78	2.50	64	2.12 hex	54 hex	5	2.7
2	50	6.80	172	3.19	81	3.19	81	2.75 hex	70 hex	7	3.2
3	80	7.48	190	4.19	106	4.62	117	4.00 hex	102 hex	12	5.5

SERIES 7000 Flo-GAGE

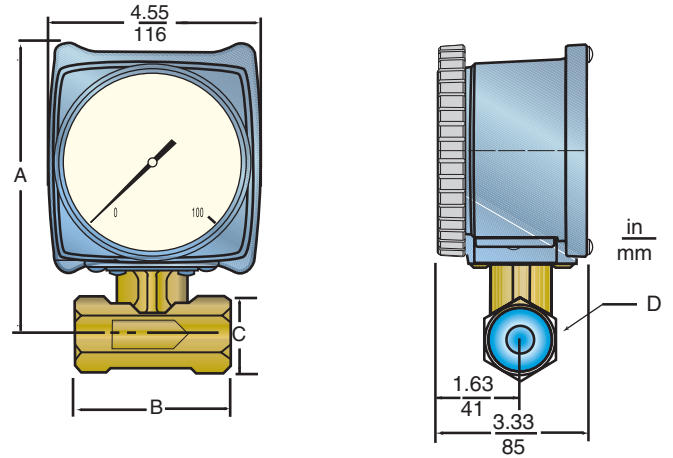

SERIES 8000

Size		A		B		Shipping Weight (typ.)	
in	mm	in	mm	in	mm	lb	kg
1/2	15	6.62	168	1.69	43	4	1.8
3/4	20	7.06	179	2.00	51	5	2.3
1	25	7.25	184	2.38	60	5	2.3
1-1/2	40	7.81	198	3.12	79	7	3.2
2	50	8.00	203	3.75	95	8	3.6
2-1/2	65	8.54	217	4.25	108	9	4.1
3	80	8.87	225	5.00	127	11	5.0
4	100	9.95	252	6.13	156	15	6.8
5	125	10.36	263	7.38	187	20	9.1
6	150	11.05	280	8.38	213	24	10.9
8	200	12.30	311	10.38	264	33	15.0

SERIES 8000 Flo-GAGE

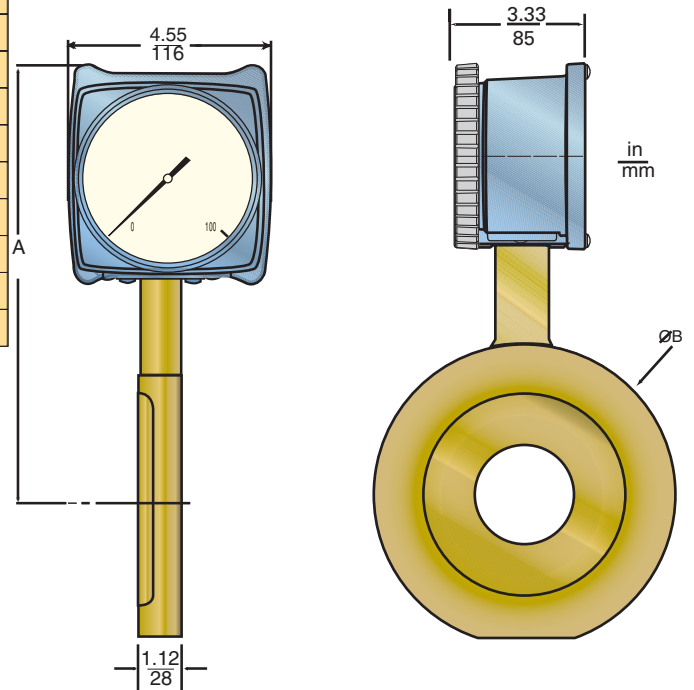

Note: "A" dimension subtract 2.00 inches (51 mm) for option W3

DIMENSIONS