

INSTALLATION ADJUSTMENT SERVICE

MANUAL HOT AND COLD WATER MIXERS

(MIX STEAM AND WATER OR HOT AND COLD WATER)

SW

CWH

CW

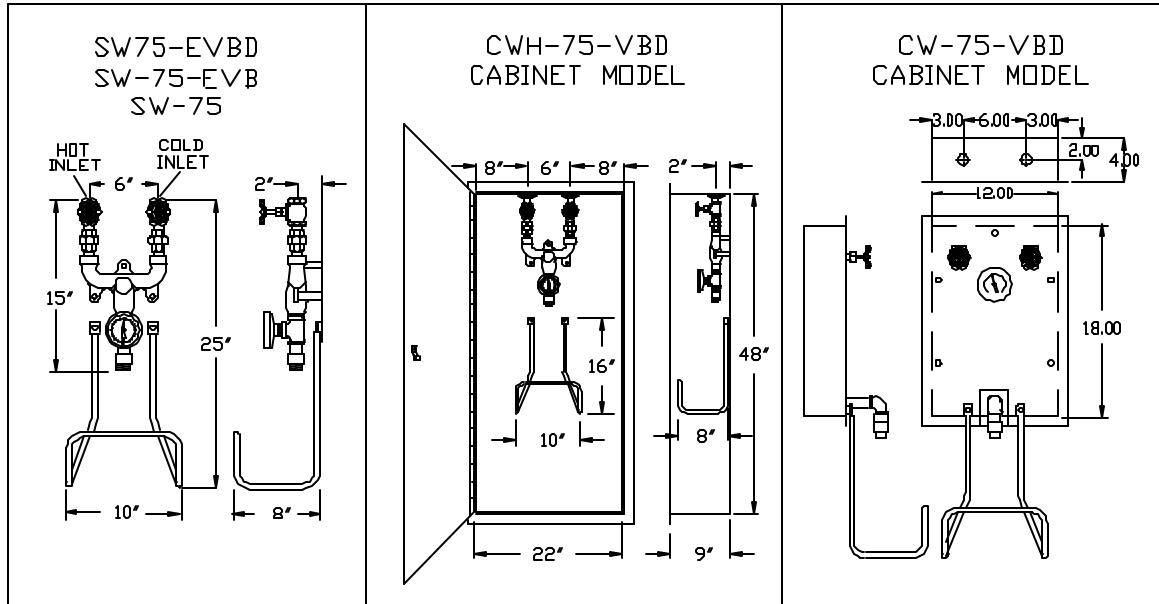

MAXIMUM SUPPLY PRESSURE: 125 PSI

Blender should be installed at a location where it can be easily adjusted, cleaned, or repaired. Connect hot water into left hand (HOT) inlet and cold water into the right hand (COLD) inlet. Use, solder or pipe cement sparingly. Supply pipes must be flushed before the blender is connected. Flush blender as soon as it is connected.

To operate **FIRST** open the right hand COLD (Blue) stop and check valve, THEN open the left hand HOT (Red) stop and check valve. Manually blend the hot and cold valves to reach the desired washdown temperature.

WHEN USING FOR HIGH TEMPERATURE WASHDOWN IN THE RANGE OF 140°F TO 180°F, OPERATORS SHOULD BE PROVIDED WITH PROTECTIVE GLOVES, BOOTS, AND CLOTHING. THEY SHOULD ALSO BE GIVEN SAFETY INSTRUCTIONS IN THE USE OF HIGH TEMPERATURE HOT WATER.

BLENDER PARTS

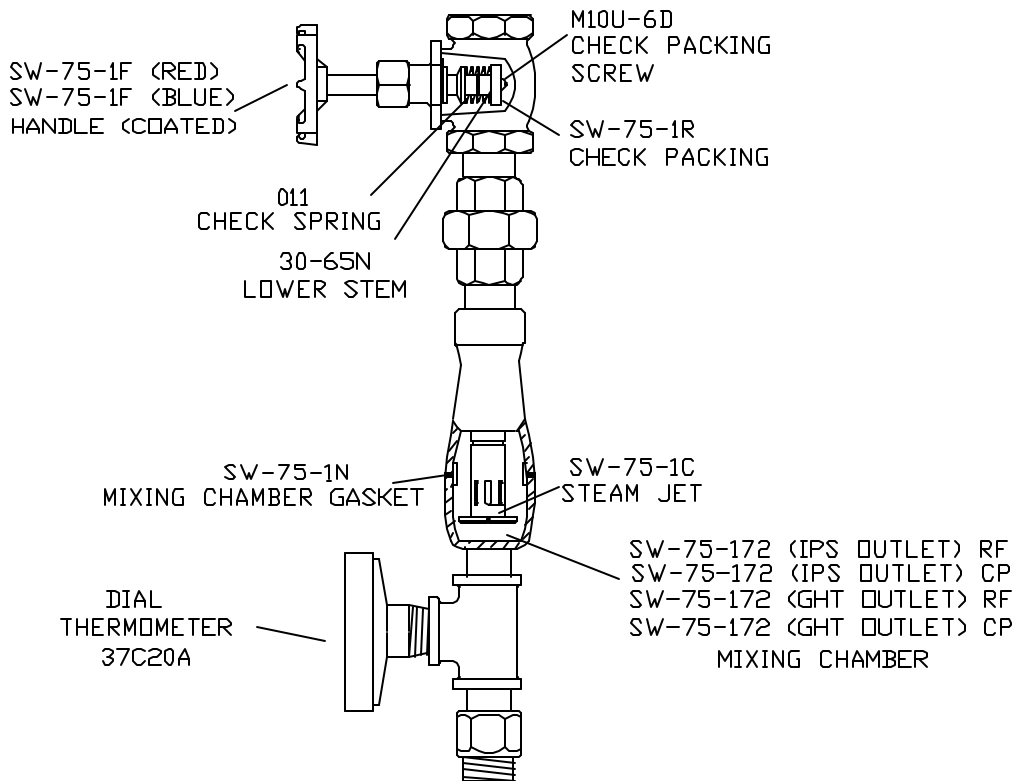

REMEMBER! THIS IS A CONTROL DEVICE WHICH MUST BE CLEANED AND MAINTAINED ON A REGULAR BASIS, DEPENDING ON WATER CONDITIONS AND USAGE. (SEE MAINTENANCE GUIDE AND RECORD MGR-1000).

LIMITED WARRANTY

Leonard Valve Company warrants the original purchaser that products manufactured by them (not by others) will be free from defects in materials and workmanship under normal conditions of use, when properly installed and maintained in accordance with Leonard Valve Company's instructions, for a period of one year of shipment. During this period the Leonard Valve Company will at its option repair or replace any product, or part thereof, which shall be returned, freight prepaid, to the Leonard factory and determined by Leonard to be defective in materials or workmanship. There are no warranties, express or implied, which extend beyond the description contained herein. There are no implied warranties of merchantability or of fitness for a particular purpose. In no event will Leonard be liable for labor or incidental or consequential damages. Any alteration or improper installation or use of the product will void this limited warranty.

Northeast Controls Incorporated ☐
P.O. Box 275 - 123 Pleasant Avenue ☐
Upper Saddle River, New Jersey 07458 USA ☐
Tel: 201-327-7660 | Fax: 201-327-3242 | sales@nciweb.com