

MATERIAL: SEE B/M
 DRAWN: TFK
 CHECKED: DEP
 SCALE: NONE
 DATE: 9-15-95



UNIGLAS TYPE III
 FULL FACE FLANGE WINDOW

Section: T400
 Bulletin: T400.52a
 Date: 12/01/00
 Supersedes: 9/20/99

FULL ASME RATED

FILE NO.: T400-52A.DWG

PARTS LIST

PIECE NO.	NAME OF PART	QUAN.	MATERIAL	COMMENTS
1	RETAINER	1	STEEL	
2	UNIGLAS	1	SEE BELOW	
3	SEAL GASKET	1		
4	CUSHION GASKET	1	FIBER	

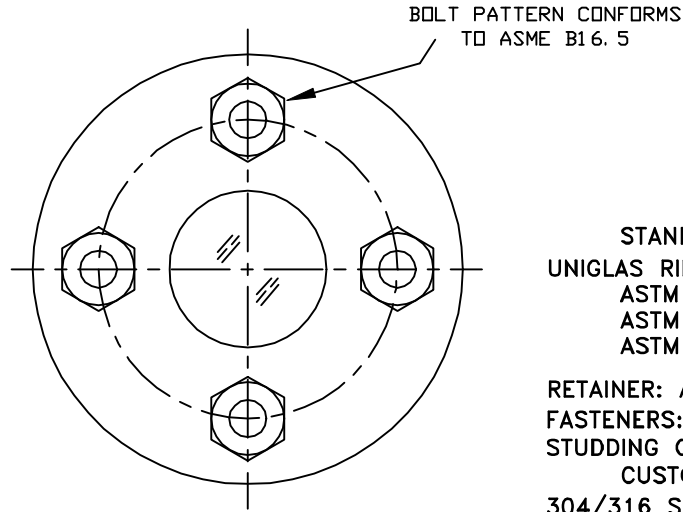

STANDARD DESIGN MATERIALS:
 UNIGLAS RING:
 ASTM A240-316L SS (1-1/2")
 ASTM B574, B575 HASTELLOY C
 ASTM A516-70 STEEL
 RETAINER: ASTM A-105 (STEEL)
 FASTENERS: CUSTOMER SUPPLIED
 STUDDING OUTLET/NOZZLE BODY:
 CUSTOMER SUPPLIED
 304/316 SS RETAINER AVAILABLE

ASME CLASS PRESSURE/TEMP RATINGS

TEMP F	150 CLASS		300 CLASS		600 CLASS	
	STEEL	316 SS	STEEL	316 SS	STEEL	316 SS
-20 TO 100	285	275	740	720	1480	1440
150	270	260	705	670	1415	1340
200	260	240	675	620	1350	1240
250	245	230	665	590	1335	1180
300	230	215	655	560	1315	1120
350	215	205	645	535	1290	1075
400	200	195	635	515	1270	1030
450	185	180	615	495	1235	990
500	170	170	600	480	1200	955

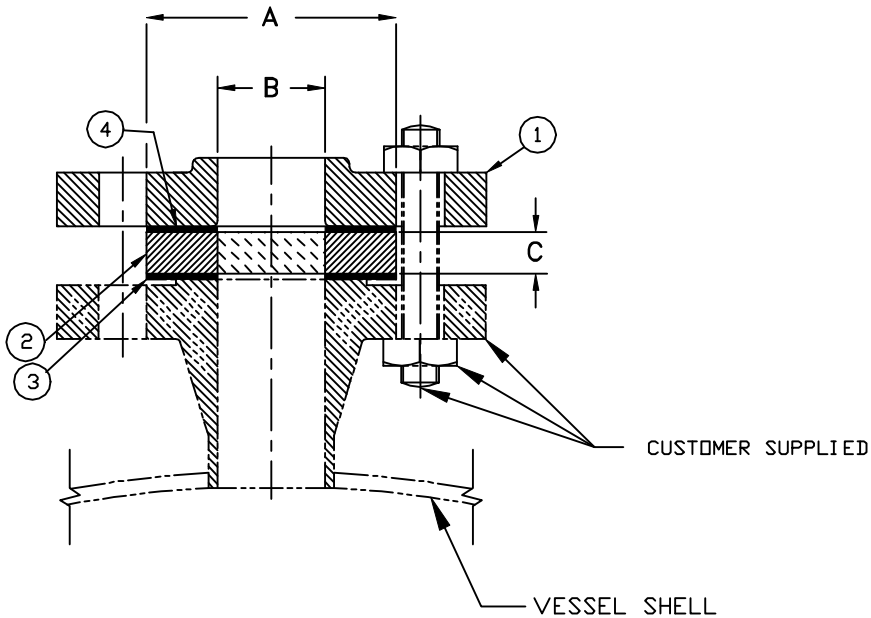

SIZE	CLASS	A (IN)	A (mm)	B (IN)	B (mm)	C (IN)	C (mm)
1	150	2.00	50.8	1.12	28.6	.75	19.0
	300	2.00	50.8	1.12	28.6	.38	9.5
	600	2.00	50.8	1.25	31.8	.75	19.0
1-1/2	150	3.00	76.2	1.50	38.1	.75	19.0
	300	TBA					
	600	TBA					
2	150	3.62	91.9	2.12	53.8	.75	19.0
	300	3.00	76.2	2.12	53.8	.75	19.0
	600	3.00	76.2	1.50	38.1	.75	19.0
2-1/2	150	4.00	102	2.50	63.5	.75	19.0
	300	TBA					
	600	4.00	102	2.50	63.5	.90	22.9
3	150	5.00	127	3.00	76.2	.75	19.0
	300	5.00	127	3.00	76.2	.90	22.9
	600	5.00	127	3.00	76.2	1.18	30.0
4	150	6.00	152	4.00	102	.75	19.0
	300	6.00	152	4.00	102	.90	22.9
	600	6.00	152	4.00	102	1.18	30.0
6	150	8.38	213	6.00	152	.75	19.0
	300	8.38	213	6.00	152	.90	22.9
	600	8.38	213	4.00	102	1.18	30.0
8	150	10.50	267	8.00	203	.90	22.9
	300	10.50	267	8.00	203	1.40	35.6
	600	TBA					
10	150	12.00	305	9.50	241	.90	22.9
	300	12.00	305	9.50	241	1.40	35.6
	600	TBA					

THIS DRAWING AND ALL INFORMATION ON IT IS THE PROPERTY OF JACOBY-TARBOX, DIVISION OF THE CLARK-RELiance CORPORATION. IT IS CONFIDENTIAL AND IS GIVEN TO YOU FOR A LIMITED PURPOSE AND MUST BE RETURNED UPON REQUEST. NEITHER THIS DRAWING NOR ANY PART OF IT NOR ANY INFORMATION CONCERNING IT MAY BE COPIED, EXHIBITED OR FURNISHED TO OTHERS NOR MAY PHOTOGRAPHS BE TAKEN OF ANY ARTICLE FABRICATED OR ASSEMBLED FROM THIS DRAWING WITHOUT CONSENT OF THE CLARK-RELiance CORPORATION.