



## MAGNE-SONICS® MS Series 2 Wire 24V Loop Powered Ultrasonic Level Transmitters

### FEATURES

- 2 Wire 24Vdc loop powered
- Operating ranges up to 36 Ft.
- Measures liquid height, distance to liquid, contents or flow in open channels
- Simple push button calibration
- Built-in LCD display
- Automatic temperature compensation

### OPERATION

Ultrasonic pulses transmitted from the transmitters face are reflected from the surface of the liquid and are received back by the same transmitter. Measurement of the time delay between the transmit and receive signals enables the microprocessor controlled electronics to calculate distance to the liquid level,

Once the transmitter is programmed with bottom reference of the application – usually the bottom of the tank – the liquid depth is calculated. The microprocessor controls the loop current to give a 4-20mA output signal proportional to the level, with the liquid level reading also available on LCD display inside the enclosure. All transmitters have integral temperature compensation to maintain accuracy across the operating temperature range.

### ADVANTAGES

- Eliminates problems experienced with contacting instrumentation
- Eliminates costly installation and mounting
- Simplified set-up and operation
- Minimal maintenance once installed

### BENEFITS

- Lost cost of installation
- Low cost of commissioning
- Minimal maintenance cost
- Process downtime minimized

Northeast Controls Incorporated □  
P.O. Box 275 - 123 Pleasant Avenue □  
Upper Saddle River, New Jersey 07458 USA □  
Tel: 201-327-7660 | Fax: 201-327-3242 | sales@nciweb.net □  
<http://www.nciweb.net/magnesonics>

## MS Advanced ultrasonics

This new family of ultrasonic non-contacting liquid level transmitters is the latest generation of level measurement instrumentation from Magne-Sonic. Proven in thousands of applications in many industries, state of the art electronics coupled with time proven ultrasonic transducer technology has resulted in an easy to use instrument with the high reliability and quality readings usually associated with more expensive products.

Choose the MS422 entry level model for simple level measurement, or select the MS400RH with 2 integral relays to add local control functionality. For hazardous areas, the MS900GH is intrinsically safe certified.

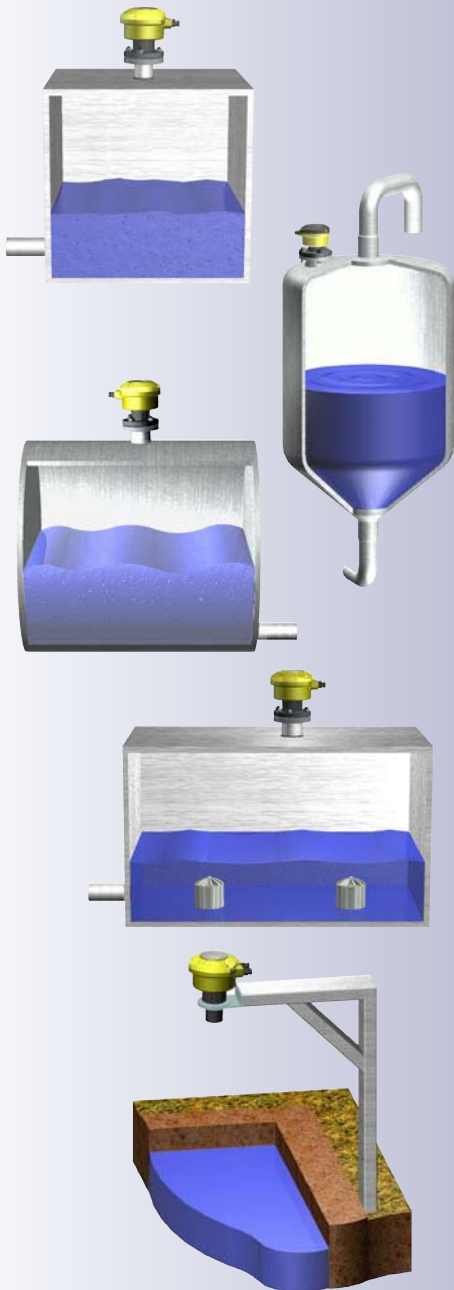

### Features

- ▶ 2 Wire 24V dc loop powered
- ▶ Operating ranges up to 36ft
- ▶ Measures liquid height, distance to liquid, volume or flow in open channels
- ▶ Simple push button calibration
- ▶ Built-in LCD display
- ▶ Automatic temperature compensation

### Advantages

- ▶ Eliminates problems experienced with contacting instrumentation
- ▶ Eliminates costly installation and mounting
- ▶ Simplified set-up and operation
- ▶ Minimal maintenance once installed

### Benefits

- ▶ Lost cost of installation
- ▶ Low cost of commissioning
- ▶ Minimal maintenance costs
- ▶ Process downtime minimised

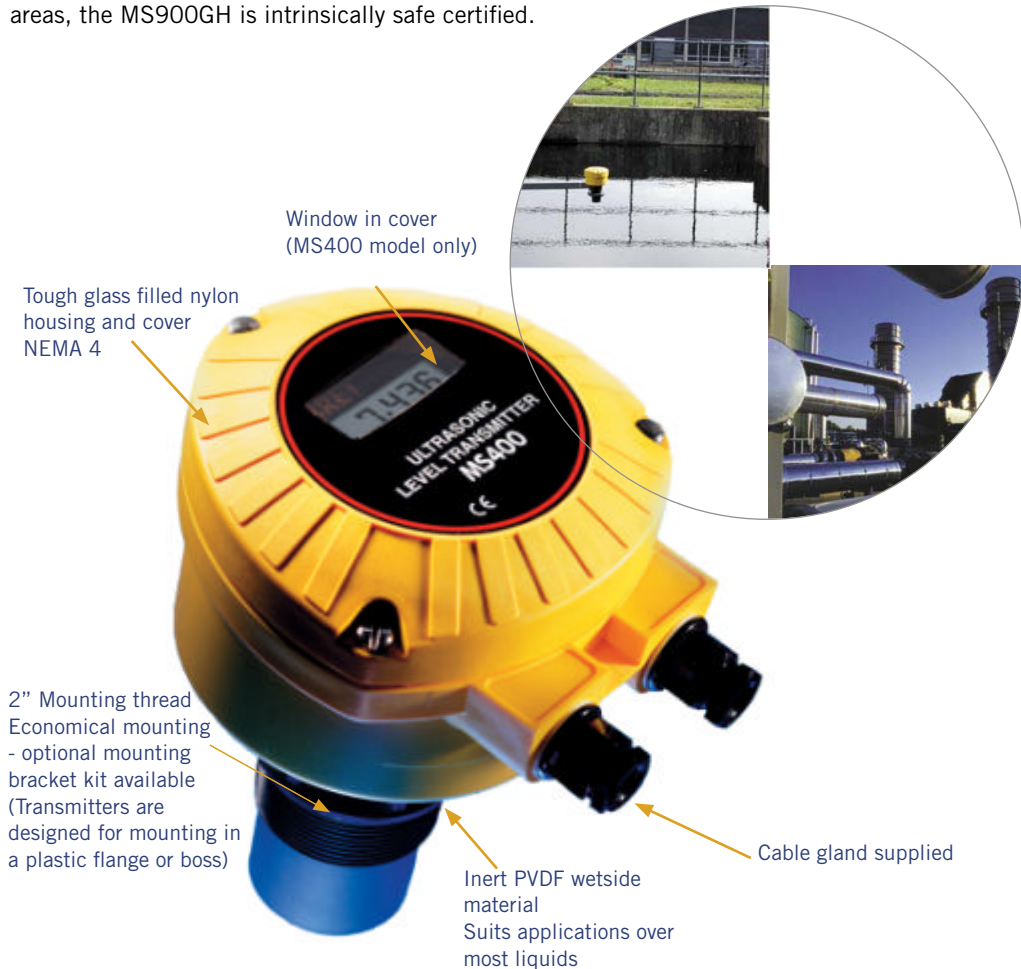

## Easy to use local menu programming

Once installed using the 2" thread, either directly to the vessel or on a suitable bracket above the liquid surface, 3 internal buttons are used to programme the transmitter with the tank depth and the range for the 4-20mA output.

A built-in LCD display under the cover is provided to aid setting up.

The user navigates through an intuitive menu, entering data as prompted by the transmitter. Intelligent software ensures only data specific to the chosen application is requested, minimising programming time.

### Programming using a PC or HART compatible communicator

The MS400RH and MS900GH are HART compatible and may be accessed remotely on the 2 wire loop. Using Magne-Sonic H-Conf401, the user can access all set-up and diagnostic parameters for interrogation or change.

Alternatively, universal HART programming tools loaded with the transmitter Device Description (from the HART foundation CD) may be used. If the DD is not loaded, the user can still access and change some parameters using universal and some common practice commands.



## Operation

Ultrasonic pulses transmitted from the transmitter face are reflected from the surface of the liquid and are received back by the same transmitter.

Measurement of the time delay between the transmit and the receive signals enables the microprocessor controlled electronics to calculate distance to the liquid level.



Once the transmitter is programmed with the bottom reference of the application - usually the bottom of the tank - the liquid depth is calculated. The microprocessor controls the loop current to give a 4-20mA output signal proportional to the level, with the liquid level reading also available on the LCD display inside the enclosure. All transmitters have integral temperature compensation to maintain accuracy across the operating temperature range.

### Choosing the right model

Each of the three models in the MS range provide features which make them suitable for specific duties, as shown below:

Simple level measurement		
Model	26ft range	MS422
	36ft range	MS400RH
Level measurement and local relays		
Model	36ft range	M400RH
Level measurement in a hazardous area		
Model	36ft range	MS900GH
Flow or volume measurement		
Model	Safe area	MS400RH
	Hazardous area	MS900GH

## Technical specifications

	MS422 	MS400RH 
Duty	Level, distance	Level, distance, volume, flow
Measuring range	1.0ft to 26ft	1.5ft to 36ft
Process temperature	-4°F to +158°F	-22°F to +158°F
Power supply	2 wire, 24V dc loop powered	2 wire, 24V dc, loop powered
Output	4-20mA	4-20mA
Digital communications	None	HART
Integral relays	None	2 x SPST 1A @ 24V dc
External temperature probe option	None, integral only	Accepts MS-RTP input (see accessories)
Certification	Safe area use only FM General electrical use	Safe area use only FM General electrical use (Pending)
Ordering information	MS422-B28: 2" BSPT mounting MS422-N28: 2" NPT mounting	MS400RH-B28: 2" BSPT mounting MS400RH-N28: 2" NPT mounting

## MS422

Entry level



The MS422 entry level transmitter is designed specifically for use in the many industrial applications where economical liquid level measurement with a 4-20mA output proportional to level is required.

The tough weatherproof nylon body and corrosion resistant PVDF wetside make the MS422 suitable for a wide range of applications.

Installation is simple and economic using the 2" thread. (Mounting bracket available as an optional extra.)

Programming is achieved in under two minutes with minimal data entry required.

### Applications

- ▶ Filter bed level
- ▶ Storage tank levels
- ▶ Effluent pits
- ▶ Reservoir level

## MS400RH

The MS400 level transmitter offers all the features of the entry level MS422 with the addition of HART digital communications and two integral relays to provide local control functionality over an increased range of 36ft. The relays are signal relays designed to operate in alarm or fault mode.

The user may also choose to configure the MS400 to calculate volume in a vessel or flow in an open channel according to several pre-programmed laws:-

- ▶ Horizontal cylinder or sphere
- ▶ 5/2 and 3/2 flow laws
- ▶ Parshall flumes
- ▶ Manning formula

Alternatively, a 10 point DIY curve is available (use HART programmer for this mode).

### Applications

- ▶ Inventory control
- ▶ Buffer tanks
- ▶ Open channel flow

Integral relays



# MS900GH

Intrinsically Safe



The MS900GH level transmitter is intrinsically safe certified for use in hazardous areas. Power must be supplied through a suitable I.S. barrier. Hart digital communications are also provided.

With a PVDF wetside, the MS900GH can be used in most hazardous and corrosive applications.

The MS900GH may be used to measure distance, level or calculate volume or flow in an open channel according to several pre-programmed laws:-

- ▶ Horizontal cylinder or sphere
- ▶ 5/2 and 3/2 flow laws
- ▶ Parshall flumes
- ▶ Manning formula

Alternatively, a 10 point DIY curve is available (use HART programmer for this mode).

### Applications

- ▶ Inventory control
- ▶ Buffer tanks
- ▶ Open channel flow

## Accessories

### MS-RTP remote temperature probe

The MS-RTP probe is designed to be used with the MS400RH and MS900GH transmitters in applications where fast ullage temperature changes or unrepresentative transmitter temperatures are a problem. The probe is simply installed in the vessel ullage space or in a shaded area of an open channel and wired back to the transmitter using the 16ft of cable provided. When the MS-RTP is connected the integral temperature probe is automatically over-ridden.

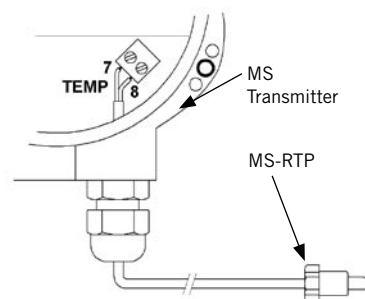

### MS-BRK mounting bracket

316 Stainless Steel angle bracket with UPVC mounting boss to facilitate transmitter installation.

MS-BRK2: 2" BSPT fitting

MS-BRK3: 2" NPT fitting

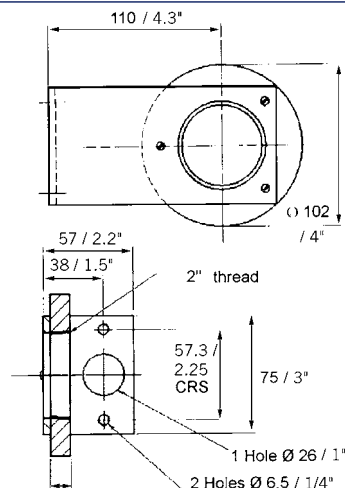

### Magne-Sonic H-CONF401 programming tool

This Windows based PC software package allows full remote interrogation and programming of the MS400 and MS900 transmitters using the HART protocol.

The product comprises a CD with software and manuals, plus a HART modem and a hard-key.

Modems and hard-keys are available in USB or serial/parallel forms.



<b>MS900GH</b>	
Level, distance, volume, flow	
1.5ft to 36ft	
-22°F to +158°F	
2 wire, 24V dc loop powered	
4-20mA	
HART	
None	
Accepts MS-RTP input (see accessories)	
ATEX II 1 G EEx ia IIC T6	
CSA (C & US) Intrinsically safe (pending)*	
MS900GH-A: 2" BSPT mounting ATEX	
MS900GH-U: 2" NPT mounting CSA*	

ADDITIONAL TECHNICAL DATA		
Ambient temperature	MS400/900:	-40°F to +140°F
	MS422:	-4°F to +158°F
Operating pressure		-3.6psi to + 43psi
Accuracy*	MS400/900:	<3.3 ft; +/- 0.1"
		>3.3ft; +/-0.25% of measured range
	MS422:	<3.3ft; +/-0.2"
		> 3.3ft; +/-0.5% of measured range
Resolution		< 1/16"
Weatherproof rating		NEMA 4
Materials of construction		Dryside: Glass filled nylon; Wetside: PVDF
Weight		2lb
Electromagnetic compatibility		EN61326 Class B

\* The product is being tested by CSA in accordance with Canadian and UL standards. It will then be certified accordingly.

\* Under reference conditions



## Magne-Sonic universal control units: ideal for programming & control of the MS range of transmitters



The MCU900 series of wall and panel mounting control units provide comprehensive control functionality for any 4-20mA or HART compatible transmitter. A back-lit display gives clear visual indication of the measured value and status of all inputs and outputs.

Mounted in a non-hazardous area, the mains powered MSC900 provides a protected 24V dc power supply to the transmitter, which may be installed in a hazardous area.

5 relays are provided and are fully field programmable to perform a wide variety of control, fault indication or alarm duties.

### Control unit features and application

- ▶ Tough weatherproof wall mount enclosure for internal or external mounting. Panel mount units require just 6.5" clearance behind the panel
- ▶ Accepts any 4-20mA or HART compatible input, allowing standardisation of control units

display.

- ▶ Supports two voltage free contact closure inputs, allowing override of control functions on external triggers.
- ▶ Pre-programmed tank shapes, flow algorithms and pump control routines simplify configuration. A 20 point DIY facility is provided for non-standard applications
- ▶ Real time clock allows energy saving routines and pump efficiency calculations.
- ▶ 5 voltage free SPDT relays for alarm and control duties.
- ▶ 4-20mA 12 bit isolated current output proportional to calculated value.

## Magne-Sonic sump transmitter: factory sealed for wetwell applications



The MS900SH is a sealed 4-20mA loop powered level transmitter specifically designed for use in waste water and effluent treatment plant on aqueous applications.

Certified Intrinsically Safe for use in Zone 0 areas, the rugged UPVC transmitter is factory fitted with up to 165ft of two core cable for simple low cost installation in sumps, wet-wells and over open channel flow structures.

The MS900SH can be connected directly to a plant control system or used with a Magne-Sonic MSC900 Control unit.

- ▶ 4-20mA output proportional to measured or calculated value.
- ▶ Factory sealed NEMA 6P for use in wet-wells and sumps up to 39ft deep.

Option of submersion shield to protect transmitter face from contamination if well is subject to flooding.

- ▶ Rugged all UPVC construction ideal for application on exposed sites such as reservoirs, rivers or remote works.
- ▶ Supplied complete with 316SS mounting bracket and 1" lock nut to facilitate fast and low cost installation using either rigid or suspension mounting methods.



## Wiring diagram

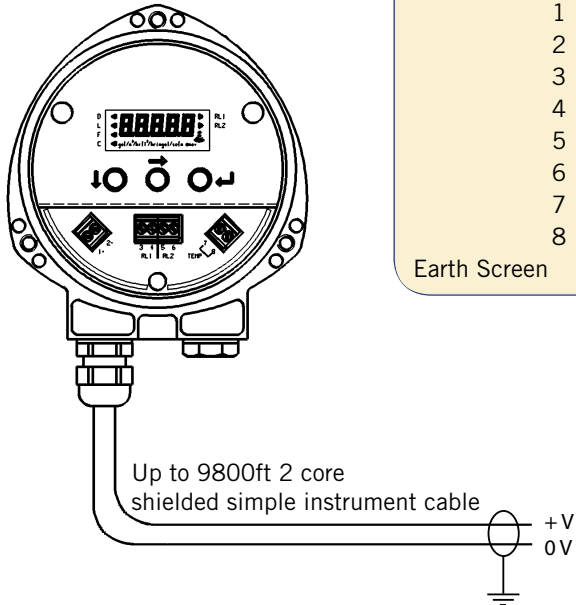

### Terminal

1	: +24V dc	
2	: 0V dc	
3	: RL1 (SPST)	MS400 only
4	: RL1 (SPST)	
5	: RL2 (SPST)	
6	: RL2 (SPST)	
7	: MS-RTP temperature probe (if used)	
8	: MS-RTP temperature probe (if used)	
Earth Screen	: Connect to a standard earth in the control room	

	Nominal	Range	I.S. Limits
MS422	24V dc	12-30V dc	n/a
MS400	24V dc	12-40V dc	n/a
MS900*	24V dc	12-40V dc	12-30V dc
All models	Min. voltage required at terminals:- 12V dc at 21mA loop current		

\* Power must be supplied through a suitable I.S. barrier or from MSC900

## Dimensional details

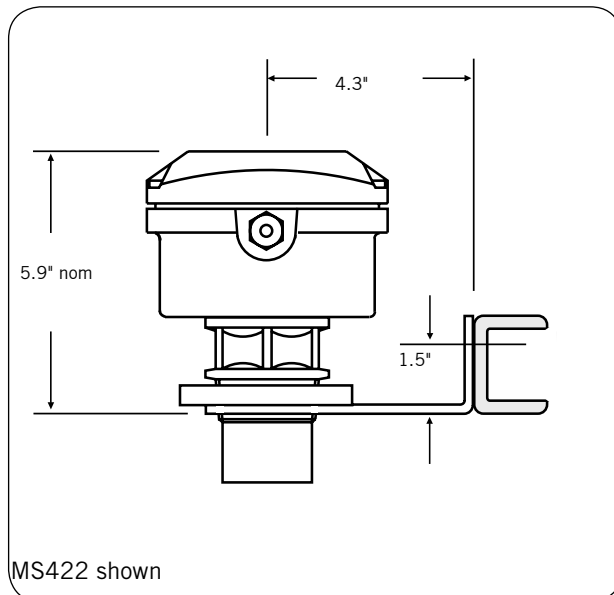
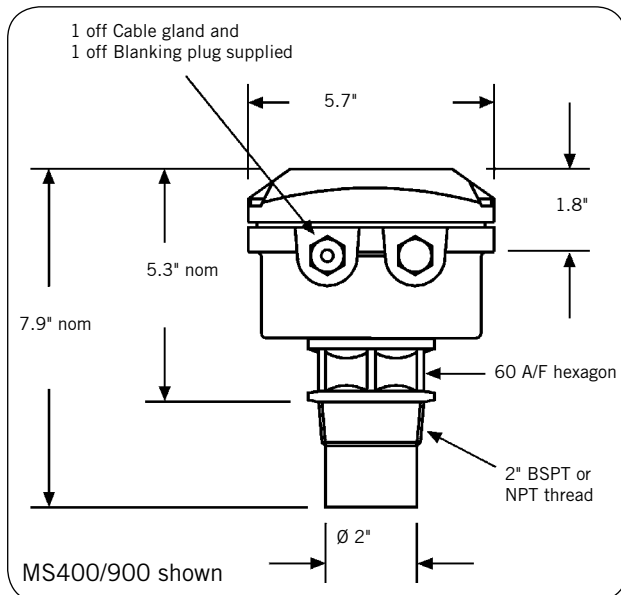

Note: Transmitters are not suitable for mounting in 2" NB pipe. A minimum of 3" NB is required. Use a plastic flange if mounting onto a tank or standpipe.

## Quality...Reliability...Service

Northeast Controls Incorporated ☐  
 P.O. Box 275 - 123 Pleasant Avenue ☐  
 Upper Saddle River, New Jersey 07458 USA ☐  
 Tel: 201-327-7660 | Fax: 201-327-3242 | sales@nciweb.net ☐  
<http://www.nciweb.net/magnesonics>